



# Product Modification Procedure

---

**PROCEDURE#:** 1233

**NUMBER OF PAGES:** 3

**DATE:** NOVEMBER 22, 1993

**TITLE:** TALON/CLASSIC, TELESIS CYPRES RETROFIT

**SERVICE BULLETIN REF:** N/A

**APPLICABLE PRODUCTS:** Talon, Talon Classic and Telesis Harness and Containers

**DESCRIPTION:** Installation of the Cypres pocket and parts to RI factory specification. This installation differs slightly from that shown in the Airtec Cypres Rigger's Installation Guide Book. However, any rigger attempting this installation should also possess a copy of the Airtec Rigger's Installation Guide Book for additional information to supplement these instructions.

**AUTHORIZED REPAIRMAN:** FAA [REDACTED] Master Rigger or Foreign Equivalent.

**MATERIALS:**

1. Airtec supplied components including processing unit pocket, EOS (cutter) elastic mount, clear plastic control unit pocket.
2. 1.5" TY-3 Tape
3. #1 Brass Spur Grommet & washer.
4. Supertack tacking thread

**MACHINES:**

Medium duty single needle, 301 stitch, 7-11 SPI.

**EQUIPMENT:**

1. Marking Pencil
2. Seam ripper
3. Handtacking needle.
4. Size #1 Spur Grommet insert set.

## PROCEDURE

### 1.0 DISASSEMBLY

- 1.1 Figure 1 shows the reserve container open and viewed from the wearer's rear. It is not necessary to open the entire corner of the reserve container to install the pocket.  
Figure E shows the modification of the reserve riser cover panel to incorporate the channel.
- 1.2 From the bartacks at the top and bottom right of the panel, unpick the stitching shown for a distance of 1.25" (32mm).
- 1.3 Using the supertack, handtack the left ends of the openings so the stitching does not pull out. The channel is now complete.

## 2.0 RE-ASSEMBLY

- 2.1 Figure A. Install the processing unit pocket onto the bottom reserve divider wall according to the instructions in the Cypres Rigger's Installation Guide Book. Orient the pocket with the cable stow pouch to the wearers right. Reinforce the corners with a minimum of three rows of backtacking 1.00" (25mm) long.
- 2.2 Figure B. Passage hole/grommet for cutter cable. Install a #1 Spur grommet in the #2 flap for the passage of cutter cable. Alternatively, a .50" (12.5mm) slit can be made in the flap with a hot knife. Either the grommet or slit must be located at the corner of the side flap where it folds back the idea being that the cable for the cutter must be routed directly from the pocket to the side channel and to the cutter elastic sleeve.
- 2.3 Figure C. Installation of a channel for the cutter cable routing . Use a piece of 1.5" TY-3 tape folded in half lengthwise. The length will vary according to the size of the reserve container. The tape should start approximately .50" up from the corner and extend past the the edge of the type 12 webbing by .75". Sew it to the binding tape with the fold facing inward.
- 2.4 Figure D. Installation of the elastic mounting sleeve for the cutter. Mount the sleeve with the binding facing inward on the flap. Place the sleeve over the cutter unit and place it so that the hole of the cutter is aligned to the outward inside edge of the grommet. Mark the edge of the sleeve. Remove the cutter and sew the sleeve to the flap through the plastic using the single needle machine.
- 2.5 Figure F. Installation of the plastic pocket for the control unit. Unpick the single row of stitching that holds the container assembly to the backpad between the zig-zag reinforcing. Insert the plastic pocket under the binding with the opening facing right. Re-stitch the top of the container to the backpad with the pocket sandwiched in between. (Note: it may be necessary to remove the reserve ripcord housing in order to complete the stitch pattern. If so, make sure that when re-tacking the housing in place that the end of the housing DOES NOT extend beyond the mouth of the retaining loop).

## 3.0 QUALITY CONTROL INSPECTION

- 3.1 Processing unit pocket- orientation, stitching, corner bartacks.
- 3.2 Passage hole or grommet.
- 3.3 Cutter cable channel.
- 3.4 Cutter elastic mounting sleeve.
- 3.5 Control cable channel- hand tacks 2 ea.
- 3.6 Control unit pocket.- Orientation.

## 4.0 REMARKS - NONE

### CONTACT PERSON:

SANDY R. REID, President  
RIGGING INNOVATIONS INC.  
27235 Watson Road,  
ROMOLAND CA 92585, USA  
TELEPHONE: (909) 9281438  
TELEFAX: (909) 928-1538  
E-MAIL ri@ix.netcom.com

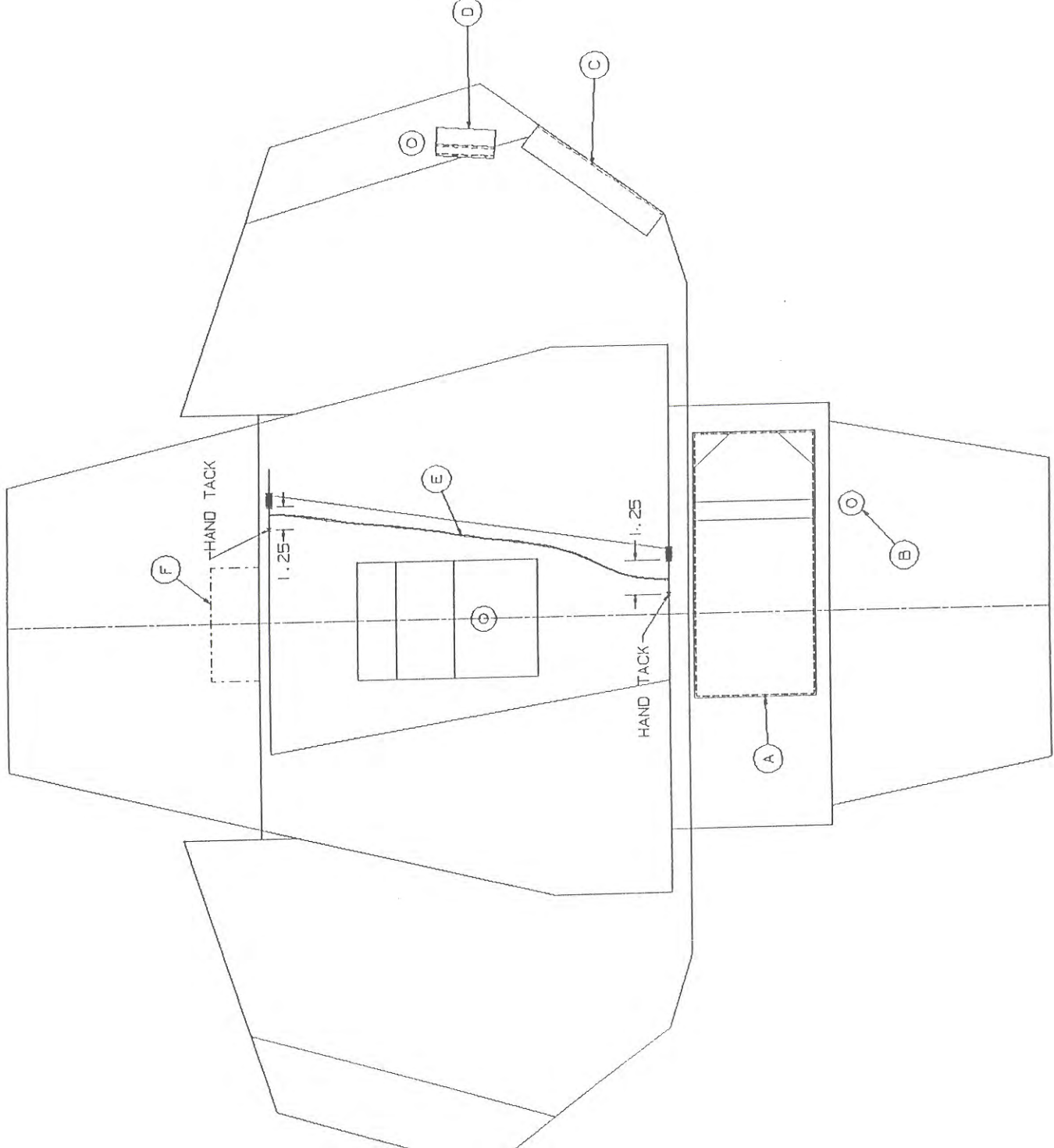

PMP-1233 FIG. 1